



General Certificate of Secondary Education  
2018

Centre Number

--	--	--	--	--

Candidate Number

--	--	--	--

# Double Award Science: Physics

Unit P2

Higher Tier



[GSD62]

\*GSD62\*

FRIDAY 15 JUNE, MORNING

## TIME

1 hour 15 minutes.

## INSTRUCTIONS TO CANDIDATES

Write your Centre Number and Candidate Number in the spaces provided at the top of this page.

**You must answer the questions in the spaces provided.**

**Do not write outside the boxed area on each page or on blank pages.**

Complete in black ink only. **Do not write with a gel pen.**

Answer **all eight** questions.

## INFORMATION FOR CANDIDATES

The total mark for this paper is 90.

Figures in brackets printed down the right-hand side of pages indicate the marks awarded to each question or part question.

Quality of written communication will be assessed in Questions **3(a)** and **8**.



1 Slinky springs can be used to demonstrate different types of wave.

One type of wave is illustrated below.



(a) (i) What type of wave is this?

\_\_\_\_\_ [1]

(ii) Describe the movement of the particles as the wave moves from left to right.

\_\_\_\_\_  
\_\_\_\_\_ [2]

The outline of a sea wave is shown below.

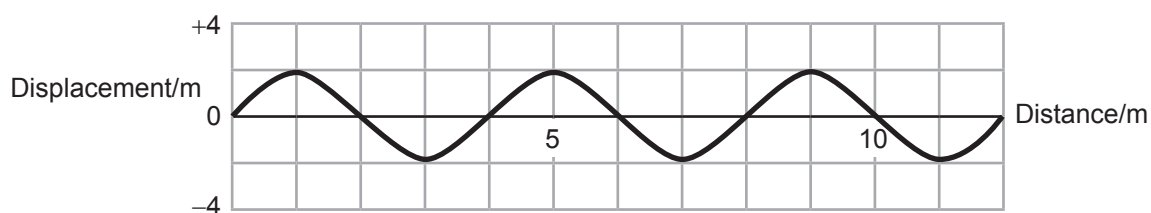

(b) (i) What do waves transfer as they move?

\_\_\_\_\_ [1]

(ii) What type of wave is a sea wave?

\_\_\_\_\_ [1]



(iii) Use the graph on the previous page to state the amplitude and wavelength of the sea wave.

Amplitude = \_\_\_\_\_ m [1]

Wavelength = \_\_\_\_\_ m [1]

(c) (i) An observer watches 60 waves passing a point in 2 minutes.

What is the frequency of the waves?

**You are advised to show your working out.**

Frequency = \_\_\_\_\_ Hz [3]

The wavelength of these waves is 6 m.

(ii) Use your answer to (c)(i) to calculate the speed of the waves.

**You are advised to show your working out.**

Speed = \_\_\_\_\_ m/s [3]

[Turn over



2 The letter N is placed in front of a plane mirror as shown below.

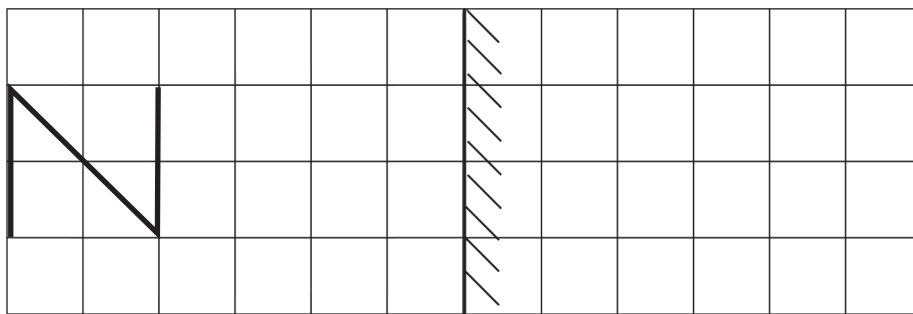

(a) Draw the reflection of the letter in the mirror.

[3]

(b) The following diagram shows a beam of white light passing through a glass prism.

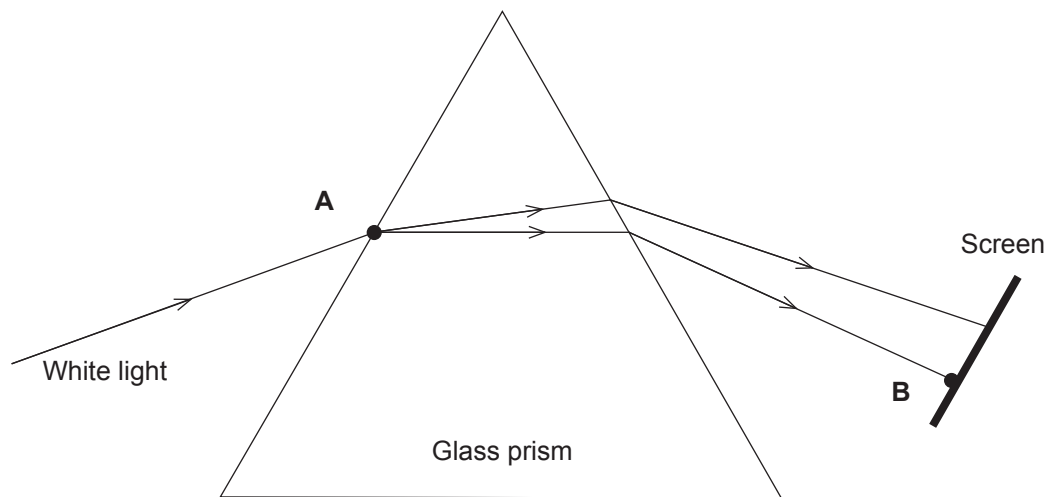

(i) What happens to the speed of light as it enters the glass at point A?

\_\_\_\_\_ [1]

(ii) The white light spreads out into different colours inside the prism.  
Name this process.

\_\_\_\_\_ [1]

(iii) State the term used to describe the full list of colours displayed on the screen.

\_\_\_\_\_ [1]

(iv) Which colour appears on the screen at point B?

\_\_\_\_\_ [1]

[Turn over

11290.06R



\*24GSD6205\*

(c) State a

(i) use of X-rays \_\_\_\_\_ [1]

(ii) danger of X-rays \_\_\_\_\_ [1]

Sonar waves are used to find the depth of the sea. The sonar waves are reflected from the sea bed. A pulse is sent out from the ship and takes 5 seconds to return to the ship.

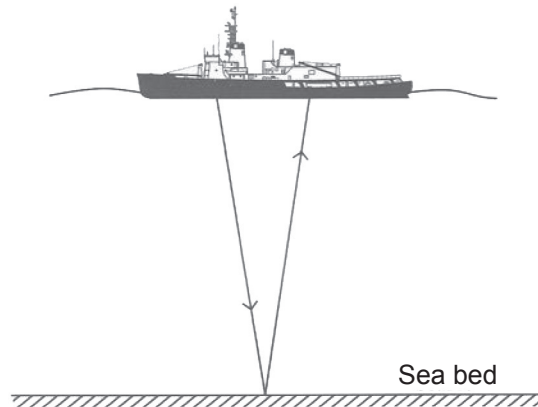

(d) If the speed of the sonar waves is 1500 m/s in water, calculate the depth of the sea.

**You are advised to show your working out.**

Depth of sea = \_\_\_\_\_ m [4]





**3 (a)** You are asked to describe the two theories that were put forward for the structure of our Solar System.

Your description should include:

- the names of the two theories;
- what is at the centre of the system in each theory;
- the name of the theory we accept today;
- the name of the main force common to both theories.

**In this question you will be assessed on your written communication skills including the use of specialist scientific terms.**

---

---

---

---

---

---

---

---

---

---

---

---

---

---

---

---

---

---

---

---

---

---

---

---

[6]

**(b)** Give the names of two bodies, other than planets, which orbit the Sun.

\_\_\_\_\_ and \_\_\_\_\_ [2]

**[Turn over**



- 4 When an object falls through the air a frictional drag force,  $F$ , acts on the object.

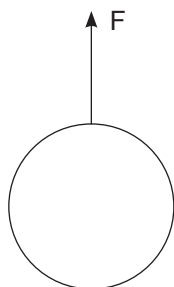

The size of the drag force,  $F$ , depends on the speed,  $v$ , of the falling object.

It is suggested that the drag force is proportional to the square of the velocity.

This relationship may be written:

$$F = kv^2 \quad \text{Equation 4.1}$$

where  $k$  is a constant.

Results are obtained and these are shown in the table below.

$F/\text{N}$	0.5	2.0	4.5	8.0	12.5
$v/\text{m/s}$	1	2	3	4	5
$v^2/\text{m}^2/\text{s}^2$		4			

- (i) Complete the table by entering the values of  $v^2$ . One value has been entered for you. [2]
- You are asked to plot a graph of  $F$  against  $v^2$ .
- (ii) Choose a suitable scale for the horizontal axis and label it. [2]
- (iii) Plot a graph of  $F$  against  $v^2$ . [2]
- (iv) Draw the best fit line. [1]





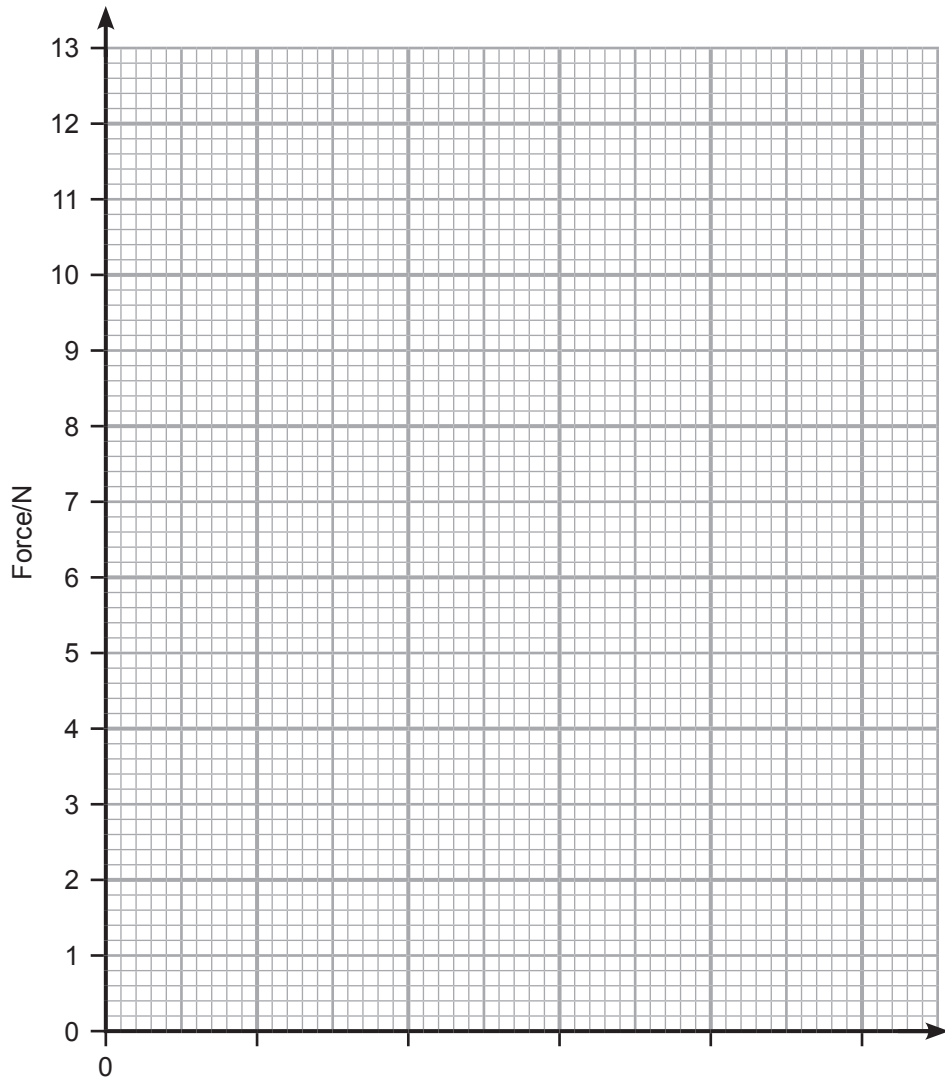

(v) Is the drag force directly proportional to  $v^2$ ?

Tick (✓) the correct box.

Yes

No

Give **two** reasons for your answer.

1. \_\_\_\_\_

2. \_\_\_\_\_ [2]

[Turn over



(vi) Use your graph to find the velocity of the falling body when the drag force acting on it is 10 N. Give your answer correct to one decimal place.

**You are advised to show your working out.**

Velocity = \_\_\_\_\_ m/s [3]





**BLANK PAGE**

**DO NOT WRITE ON THIS PAGE**

**(Questions continue overleaf)**

11290.06R

**[Turn over**



\*24GSD6211\*

5 A girl combs her hair with a plastic comb.



© Mint Images / Science Photo Library

(a) (i) State the name of the force which causes the comb to become charged.

\_\_\_\_\_ [1]

(ii) Name the particle which moves and describe how the comb has become **positively** charged.

Particle \_\_\_\_\_

Description \_\_\_\_\_ [2]



- (b) The girl notices that after she combed her hair some strands remained separated.

Explain fully why the strands of hair remained separated.

---

---

[2]

- (c) A current of 400 mA flows through a resistor for 300 seconds. Calculate the charge which flows during this time.

Remember to include the unit.

**You are advised to show your working out.**

Charge = \_\_\_\_\_ [5]



- (d) Conor uses the following circuit to find the current–voltage characteristic for a filament lamp.

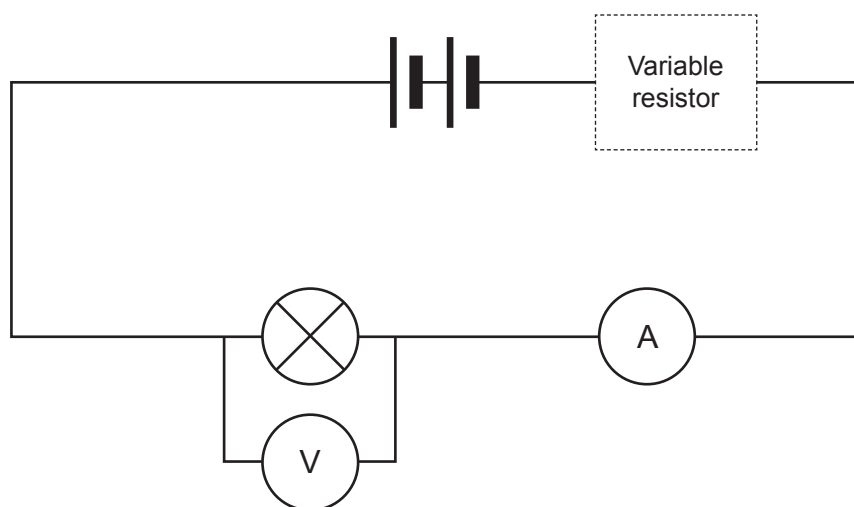

- (i) Draw the symbol for the variable resistor, in the box below.

Variable resistor



[1]

- (ii) What is the purpose of the variable resistor?

\_\_\_\_\_

[1]



(e) Sketch the graph of current against voltage which Conor would obtain.

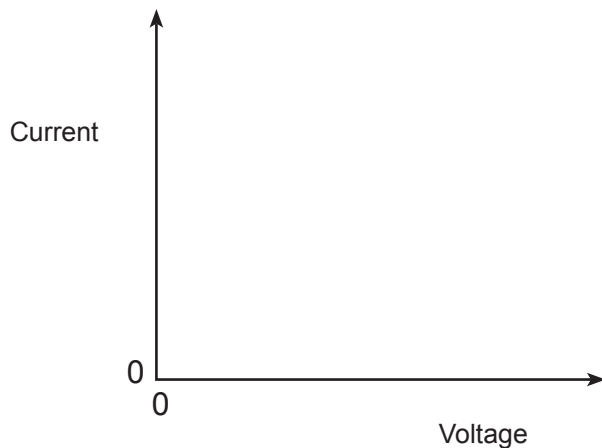

[2]

(f) What happens to the resistance of the filament lamp as the current increases?

\_\_\_\_\_ [1]

[Turn over



6 (a) (i) In the circuit below find the resistance between points P and Q.

You are advised to show your working out.

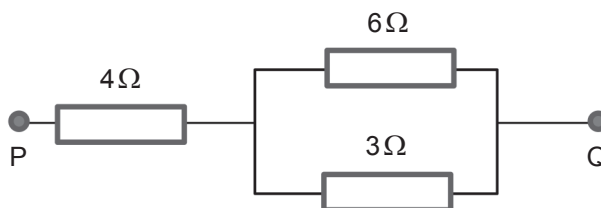

Resistance = \_\_\_\_\_  $\Omega$  [4]

(ii) When a battery is connected to points P and Q, a current of 60 mA flows through the  $4\ \Omega$  resistor. In the table below give the currents which pass through the other two resistors.

Resistance/ $\Omega$	Current/mA
6	
3	

[2]





(b) A lamp is rated at 6 V, 0.2A. This means that when a voltage of 6 V is applied a current of 0.2A flows through it and the lamp glows with normal brightness.



©Ohotnik/iStock/Thinkstock

This lamp is connected in the circuit below where it glows with normal brightness.

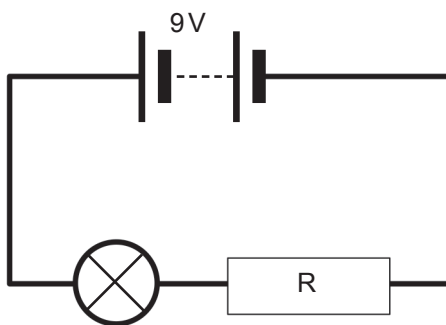

Calculate the resistance of the resistor R.

You are advised to show your working out.

R = \_\_\_\_\_  $\Omega$  [4]

[Turn over



An electric kettle connected to a 240 V supply is used to boil water.



©Bet\_Noire/iStock/Thinkstock

To boil the water requires 432 000 J of energy. The power of the kettle is 2.88 kW.

(c) How long does it take the kettle to boil the water?

Time = \_\_\_\_\_ s [4]





**BLANK PAGE**

**DO NOT WRITE ON THIS PAGE**

**(Questions continue overleaf)**

11290.06R

**[Turn over**



\*24GSD6219\*

7 (a) The apparatus below is used to demonstrate electromagnetic induction.

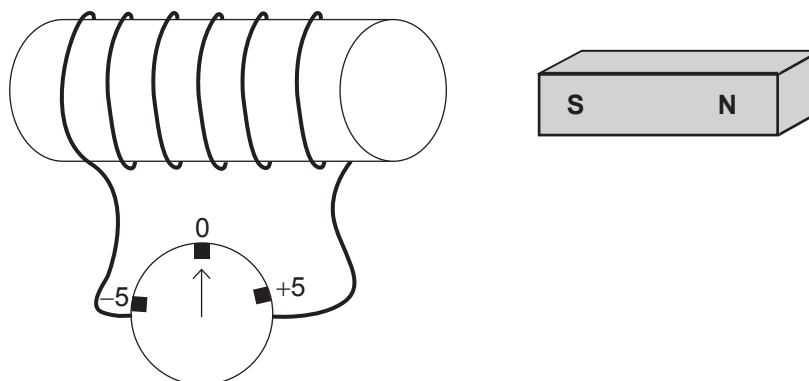

The south pole of a magnet is moved towards the coil and the ammeter gives a momentary deflection to the left as shown in the table. Complete the table to record the observations for the remaining procedures.

Procedure	Observation
S pole of magnet enters the coil	Momentary deflection to the left
S pole of magnet withdrawn from the coil	
Coil moved towards S pole of magnet	
Coil remains at rest over the magnet	

[3]



Electromagnetic induction is the process used in a transformer.

- (b) (i)** What type of transformer is used at the generation end of the electricity grid?

Type of transformer \_\_\_\_\_ [1]

- (ii)** State the purpose of this transformer.

\_\_\_\_\_  
\_\_\_\_\_ [1]

- (c) (i)** The primary coil of a transformer is connected to the mains voltage of 240 V. The number of turns on the primary coil is 1800. The secondary coil has 270 turns.

Calculate the output voltage of this transformer.

**You are advised to show your working out.**

Output voltage = \_\_\_\_\_ V [3]

- (ii)** Suggest how the output voltage from this transformer could be increased by changing the number of turns on one of the coils.

\_\_\_\_\_ [1]

**[Turn over**

11290.06R



\*24GSD6221\*

8 Describe the structure of the Earth.

Your description should include:

- what you understand by the lithosphere;
- the names of the two innermost layers and whether they are solid or liquid.

**In this question you will be assessed on your written communication skills, including the use of specialist scientific terms.**

Lithosphere: \_\_\_\_\_  
\_\_\_\_\_  
\_\_\_\_\_

Names and states of the two innermost layers: \_\_\_\_\_  
\_\_\_\_\_  
\_\_\_\_\_  
\_\_\_\_\_  
\_\_\_\_\_  
\_\_\_\_\_  
\_\_\_\_\_  
\_\_\_\_\_ [6]





---

**THIS IS THE END OF THE QUESTION PAPER**

---

11290.06R



\*24GSD6223\*

**DO NOT WRITE ON THIS PAGE**

<b>For Examiner's use only</b>	
<b>Question Number</b>	<b>Marks</b>
1	
2	
3	
4	
5	
6	
7	
8	

<b>Total Marks</b>	
--------------------	--

**Examiner Number**

Permission to reproduce all copyright material has been applied for.  
In some cases, efforts to contact copyright holders may have been unsuccessful and CCEA will be happy to rectify any omissions of acknowledgement in future if notified.

233101



\*24GSD6224\*