

Friday 9 June 2017 – Morning

**GCSE GATEWAY SCIENCE
SCIENCE B**

B712/01 Science modules B2, C2, P2 (Foundation Tier)

Candidates answer on the Question Paper.
A calculator may be used for this paper.

OCR supplied materials:

None

Other materials required:

- Pencil
- Ruler (cm/mm)

Duration: 1 hour 30 minutes



Candidate forename		Candidate surname	
-----------------------	--	----------------------	--

Centre number						Candidate number				
---------------	--	--	--	--	--	------------------	--	--	--	--

INSTRUCTIONS TO CANDIDATES

- Write your name, centre number and candidate number in the boxes above. Please write clearly and in capital letters.
- Use black ink. HB pencil may be used for graphs and diagrams only.
- Answer **all** the questions.
- Read each question carefully. Make sure you know what you have to do before starting your answer.
- Write your answer to each question in the space provided. Additional paper may be used if necessary but you must clearly show your candidate number, centre number and question number(s).
- Do **not** write in the barcodes.

INFORMATION FOR CANDIDATES

- The quality of written communication is assessed in questions marked with a pencil (✎).
- A list of equations can be found on page 2.
- The Periodic Table can be found on the back page.
- The number of marks is given in brackets [] at the end of each question or part question.
- The total number of marks for this paper is **85**.
- This document consists of **32** pages. Any blank pages are indicated.

EQUATIONS

energy = mass × specific heat capacity × temperature change

energy = mass × specific latent heat

efficiency = $\frac{\text{useful energy output (} \times 100\% \text{)}}{\text{total energy input}}$

wave speed = frequency × wavelength

power = voltage × current

energy supplied = power × time

average speed = $\frac{\text{distance}}{\text{time}}$

distance = average speed × time

$$s = \frac{(u + v)}{2} \times t$$

acceleration = $\frac{\text{change in speed}}{\text{time taken}}$

force = mass × acceleration

weight = mass × gravitational field strength

work done = force × distance

power = $\frac{\text{work done}}{\text{time}}$

power = force × speed

$$\text{KE} = \frac{1}{2}mv^2$$

momentum = mass × velocity

force = $\frac{\text{change in momentum}}{\text{time}}$

GPE = mgh

$$mgh = \frac{1}{2}mv^2$$

resistance = $\frac{\text{voltage}}{\text{current}}$

BLANK PAGE

Question 1 begins on page 4

PLEASE DO NOT WRITE ON THIS PAGE

Answer **all** the questions.

SECTION A – Module B2

- 1 (a) Climate change is one reason why organisms become extinct or endangered.

Write down **two other** reasons why organisms might become extinct.

.....
.....
..... [2]

- (b) Bushfires are fires that go out of control and can damage large areas of wild land.

Bushfires are very common in hot climates.

- (i) Many animals and plants die and then decay as a result of a bushfire.

What happens to the **elements** in their bodies after they decay?

..... [1]

- (ii) Which organisms cause dead animals and plants to decay?

Put ticks (✓) in the boxes next to the **two** correct answers.

- | | |
|----------|--------------------------|
| algae | <input type="checkbox"/> |
| bacteria | <input type="checkbox"/> |
| fungi | <input type="checkbox"/> |
| protozoa | <input type="checkbox"/> |
| viruses | <input type="checkbox"/> |

[1]

(iii) Gum trees can survive bushfires.

This is because their buds are **below** ground and protected from the fire.

After a bush fire, these buds quickly grow into new shoots.

Other trees have buds **above** ground and they get damaged by the fire.

The buds help the gum tree compete with other plants after a bushfire.

Explain how.

.....
..... [1]

2 This question is about protecting the environment.

(a) Ben and Hollie want a new fire for their living room.

They have different ideas on which fire is better for the environment.

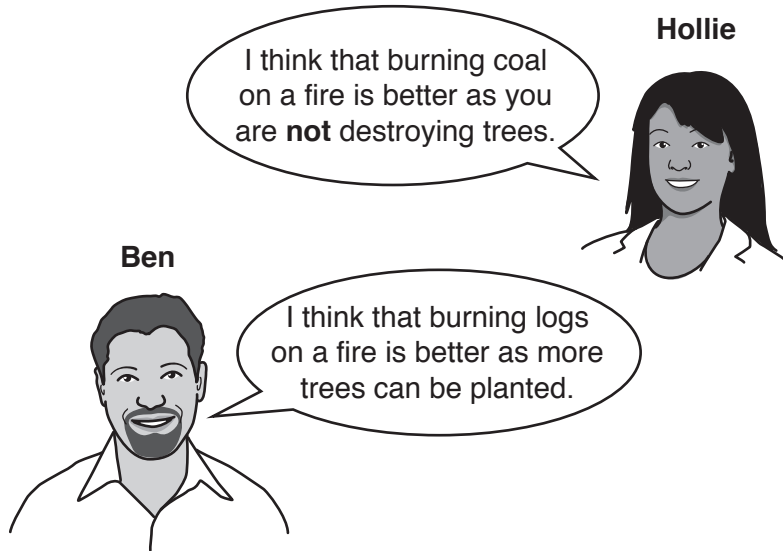

Who has the best idea on which type of fire is better for the environment?

Explain your answer.

.....
.....
..... [2]

(b) The mining of minerals out of the ground sometimes causes pollution.

Scientists are developing microbes that can remove minerals from industrial waste.

These minerals can then be used again.

This new development will affect the environment.

Explain how.

.....
.....
..... [2]

(c) Bluefin tuna are fish that are caught for food.

Fishermen are told how much bluefin tuna they can catch in one year.

This is called the **quota**.

Look at the table.

It shows the quota for bluefin tuna and the estimated total amount of bluefin tuna **actually** caught between 2005 and 2009.

Year	Quota of bluefin tuna in tonnes	Estimated total amount of bluefin tuna actually caught in tonnes
2005	32 000	48 000
2006	30 000	60 000
2007	28 000	60 000
2008	20 000	52 000
2009	12 900	46 000

(i) In 2006, the estimated total amount of bluefin tuna actually caught was 30 000 tonnes more than the quota.

This is a 100% increase on the quota.

Calculate the percentage increase on the quota for estimated catches in **2005**.

answer % [1]

(ii) The quota is designed to prevent overfishing of bluefin tuna.

Discuss reasons why the quota may or may not be preventing overfishing of bluefin tuna.

Use the information in the table and your answer to part (c)(i) in your answer.

.....

.....

.....

..... [2]

PLEASE DO NOT WRITE ON THIS PAGE

3 (a) Bees, butterflies and hummingbirds all belong to the animal kingdom.

(i) Write down **two** characteristics all organisms in the animal kingdom must have.

1

2

[2]

(ii) Bees and butterflies are arthropods.

They both have two pairs of wings and six legs.

Which group of arthropods do bees and butterflies belong to?

Choose your answer from the list.

arachnids

crustaceans

insects

myriapods

answer

[1]

(b) Bees, butterflies and hummingbirds feed on nectar.

Nectar is made in the nectary of flowers.

When they feed on the nectar, the animals will help pollinate the flowers.

Look at the table. It shows features of bees, butterflies and hummingbirds.

Animal	Mouthparts	Colour vision	Sense of smell
bee	short piercing mouthpart	can not see red but sees blue colours	good
butterfly	very long tube like mouthparts	can not see red but sees blue colours	good
hummingbird	very long pointed beak and tongue	can see red and blue colours	poor

The diagram shows a flower pollinated by animals.

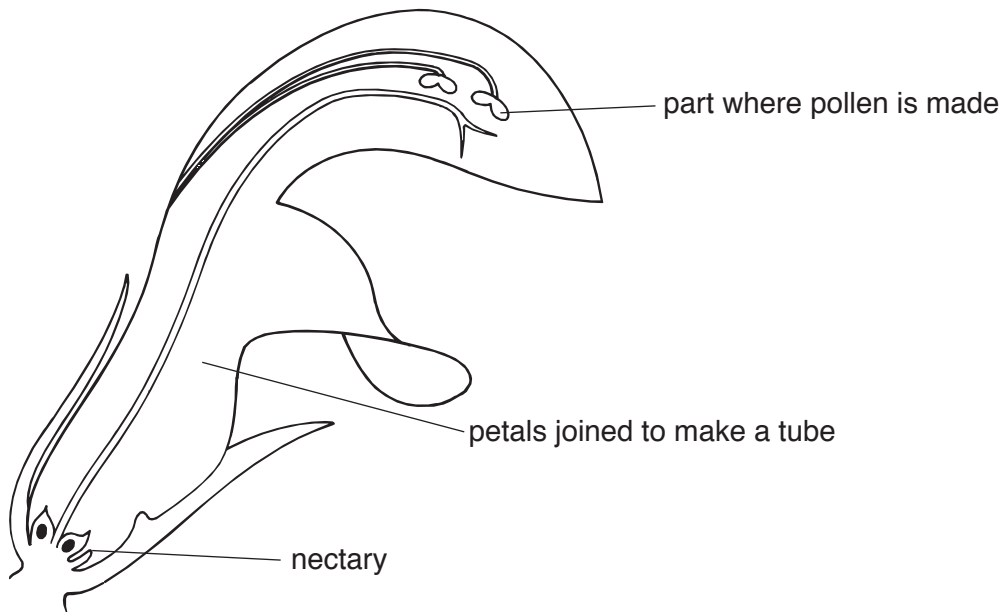

4 Look at the pictures.

They show two types of sheep.

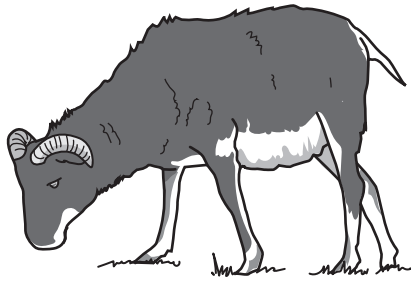

Soay sheep

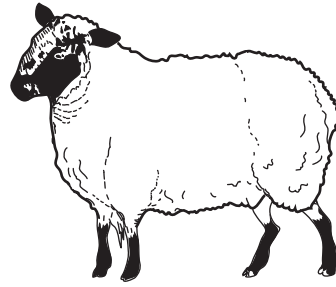

modern sheep

(a) Describe **two** ways Soay sheep are different from modern sheep.

.....

.....

.....

..... [2]

(b) There is a population of Soay sheep living on the small Scottish island of St. Kilda.

Look at the graph.

It shows the population size of Soay sheep on St. Kilda between 1985 and 2010.

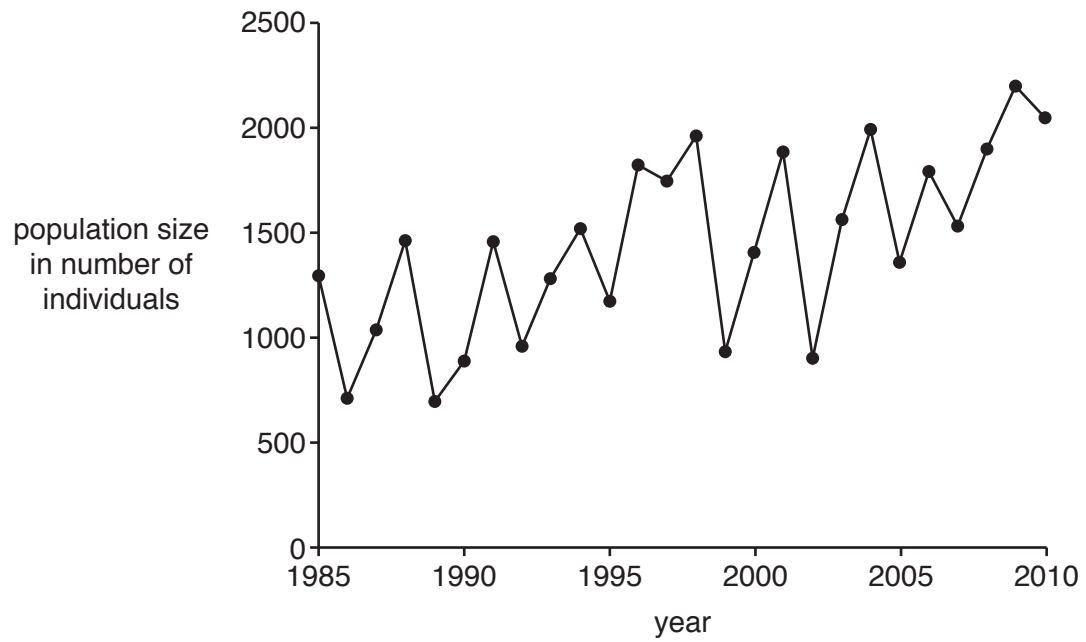

Describe the trends in the graph.

.....

.....

.....

..... [2]

SECTION B – Module C2

5 Look at the displayed formula for sulfuric acid.

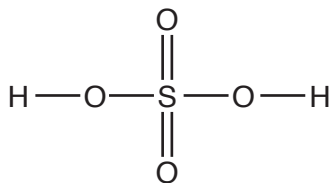

(a) How many atoms are there in one molecule of sulfuric acid?

answer [1]

(b) How many elements are joined together in sulfuric acid?

answer [1]

(c) The atoms in a sulfuric acid molecule are held together by covalent bonds.

What is the name of the **other** type of bond that holds atoms together?

..... [1]

(d) Sarah tests dilute sulfuric acid.

She wants to find the pH of the acid.

She does **not** have a pH meter.

Describe how she can find the pH of dilute sulfuric acid.

.....
.....
.....
..... [2]

(e) Which ion is found in all dilute acids?

..... [1]

6 David investigates different fertilisers.

(a) He finds this information from the internet.

Fertiliser	Percentage (%) by mass of element in fertiliser			
	Nitrogen	Oxygen	Phosphorus	Potassium
A	34	45	0	0
B	24	5	25	20
C	10	40	5	0
D	0	24	15	10

David concludes that fertiliser **B** is the best of the four fertilisers.

Does the information in the table support this conclusion?

Explain your answer using evidence from the table.

.....

.....

.....

.....

.....

.....

.....

..... [2]

(b) The manufacture of ammonia is very important in food production.

Explain why.

.....

.....

.....

..... [2]

7 The Earth is made up of several layers.



not to scale

Describe the structure of the Earth.

Explain why it is difficult for scientists to study the structure of the Earth.



The quality of written communication will be assessed in your answer to this question.

.....
.....
.....
.....
.....
.....
.....
.....
.....
.....
.....
.....
.....
.....
.....
.....
.....
.....
.....
.....

17
BLANK PAGE

PLEASE DO NOT WRITE ON THIS PAGE

- 8 Julie investigates the corrosion of aluminium and iron in different conditions. She puts an iron nail into each four stoppered test tubes. She leaves the test tubes for 2 weeks.

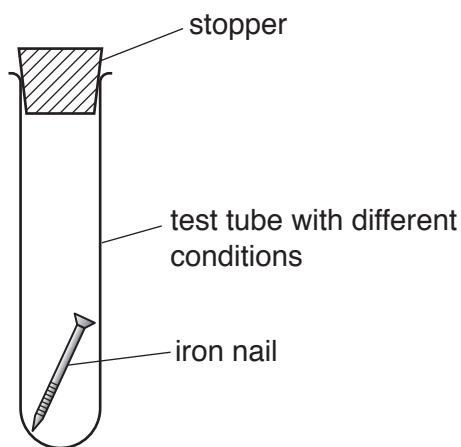

The condition inside each test tube is different.

She repeats each experiment with strips of aluminium instead of iron nails.

Look at Julie's results.

Conditions inside test tube	Result with iron	Result with aluminium
acidic moist air	nail is covered with lots of rust	very little corrosion
dry air	no rust	no corrosion
moist air	nail is covered with rust	no corrosion
moist nitrogen	no rust	no corrosion

- (a) Rusting of iron needs oxygen.

What evidence is there in the results to show that rusting needs oxygen?

.....
 [1]

- (b) Rusting of iron needs water.

What evidence is there in the results to show that rusting needs water?

.....
 [1]

(c) Look at the word equation for rusting.

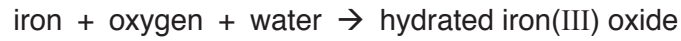

Rusting of iron is an example of **oxidation**.

How can you tell from the word equation?

.....
..... [1]

(d) Aluminium does not corrode in moist air.

This is because aluminium reacts with oxygen to form a protective layer.

This layer is aluminium oxide.

Write the **word** equation for this reaction.

..... [1]

(e) Waste aluminium and iron can be separated from one another easily.

Explain why. Use ideas about their properties.

.....
.....
..... [2]

9 Ali investigates the strength of concrete beams.

He makes some beams using a cement, sand and water mixture.

Ali reinforces the beams with steel wire.

Each beam he uses has a different mass of steel wire.

Ali measures the maximum weight the beam will support before it breaks.

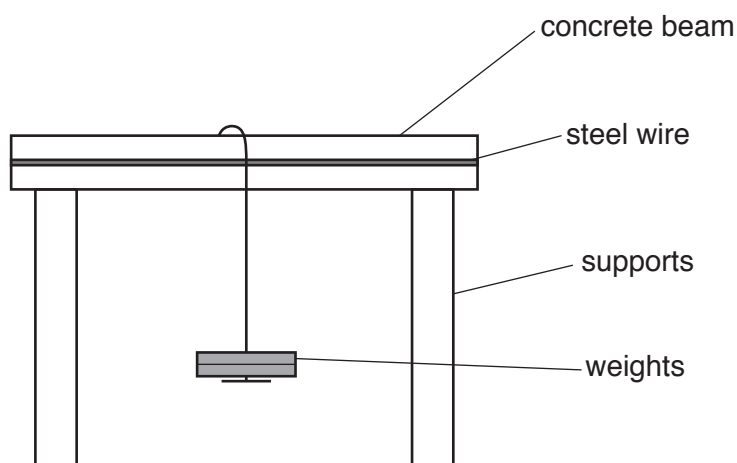

Ali repeats all the experiments so he can get a mean (average) result.

Look at Ali's results.

Mass of steel wire in g	Maximum weight supported by the beam in N		
	test 1	test 2	mean (average)
0.0	80	85	82.5
1.0	90	95	92.5
2.0	85	105	95
3.0	120	120
4.0	150	115
5.0	150	150

Complete the table and describe the pattern shown in the results.

.....

.....

..... [3]

SECTION C – Module P2

10 Scientists look for threats to Earth.

They are worried about Near Earth Objects (NEOs) such as asteroids and comets.

(a) How can NEO's be a threat to Earth?

.....
..... [1]

(b) (i) What are comets made of?

..... [1]

(ii) What feature of a comet helps them to be recognised?

..... [1]

(c) What are asteroids made of?

..... [1]

11 Look at the information on electrical appliances.

Appliance	Time switched on in hours	Average power rating in kW	Cost per unit of electricity in pence	Cost to use in pence
immersion heater	4	7.0	15	420
room lights	6	0.3	15	27
TV	12	0.4	15	72
washing machine	2	3.0	15	90
cooker	2	2.5	15	75

(a) Which appliance costs the **least** to run for one hour?

Use the data in the table to help calculate your answer.

.....

 [2]

(b) Look at the table.

Write down **two** factors that **increase** the cost of using electricity.

1
 2 [2]

(c) The cooker has a power range of 1 to 11 kW.

Suggest why the value for power in the table is only 2.5 kW.

.....

 [2]

(d) Electrical appliances can be compared using power ratings.

An electric heater has a current of 11 A when connected to the 230 V mains.

Calculate the power rating of the heater.

answer W [2]

PLEASE DO NOT WRITE ON THIS PAGE

12 (a) Bill uses a dynamo to generate electricity.

He spins the magnet at a steady speed. The current output is 0.5A.

Look at the diagram.

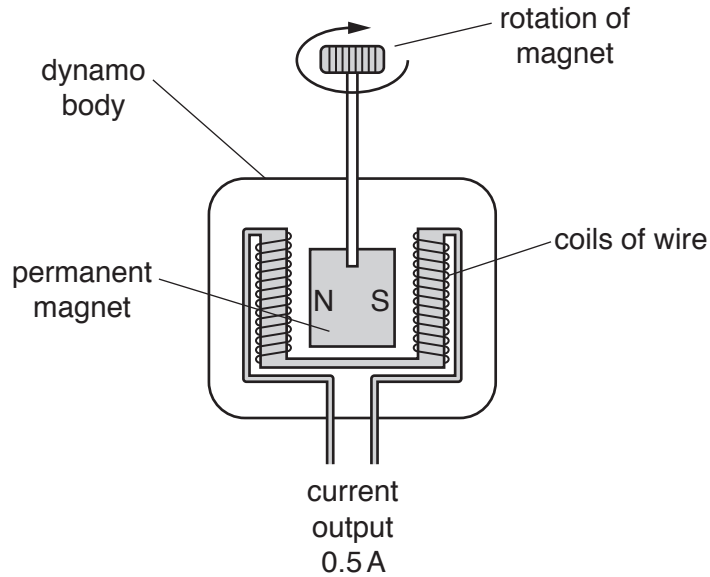

Bill wants to double the output current to 1.0A so he changes two things at once.

- he doubles the speed of rotation
- he halves the strength of the magnet.

The output current does **not** double.

Explain why and suggest the size of the output current.

.....

.....

.....

..... [3]

(b) Power stations produce energy but they waste energy too.

The efficiency target for a fossil fuel power station is 40%.

7 MJ of energy is wasted when the energy input to the power station is 12 MJ.

(i) Does this power station meet the 40% efficiency target?

Explain your answer using a calculation.

.....
.....
.....
..... [2]

(ii) Fuel is burned in power stations to produce energy.

How is this energy used to produce electricity?

.....
.....
.....
..... [2]

13 Scientists have changed their understanding of the Universe several times over many years.

Ptolemy and Copernicus had different ideas of the Universe.

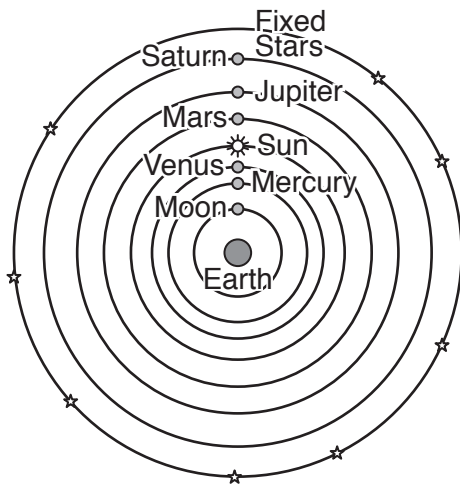

Ptolemy model
Year (about) 135

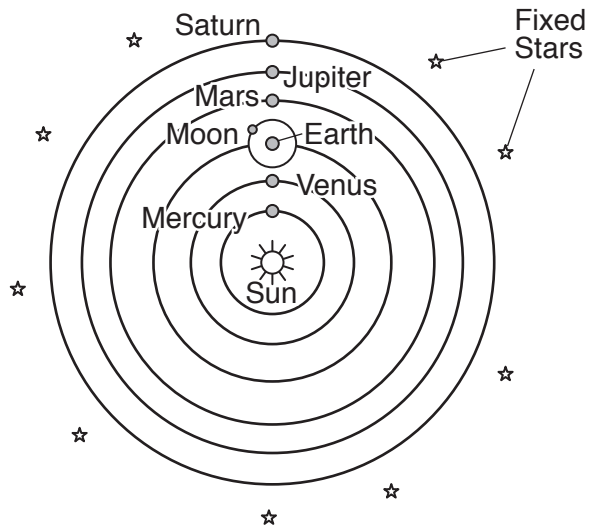

Copernicus model
Year 1543

In 2017 we have a different model of the Universe.

Describe the differences between the models in the years 135, 1543 and 2017.

Suggest why the models have changed over the years.



The quality of written communication will be assessed in your answer to this question.

.....

.....

.....

.....

.....

.....

.....

.....

.....

.....

.....

[6]

BLANK PAGE

PLEASE DO NOT WRITE ON THIS PAGE

SECTION D

14 This question is about the atmospheric pollutants:

- sulfur dioxide, SO_2
- oxides of nitrogen, NO_x

(a) Look at bar chart 1.

It shows the mass of **sulfur dioxide** pollution made in France in different ways between 1990 and 2010.

bar chart 1

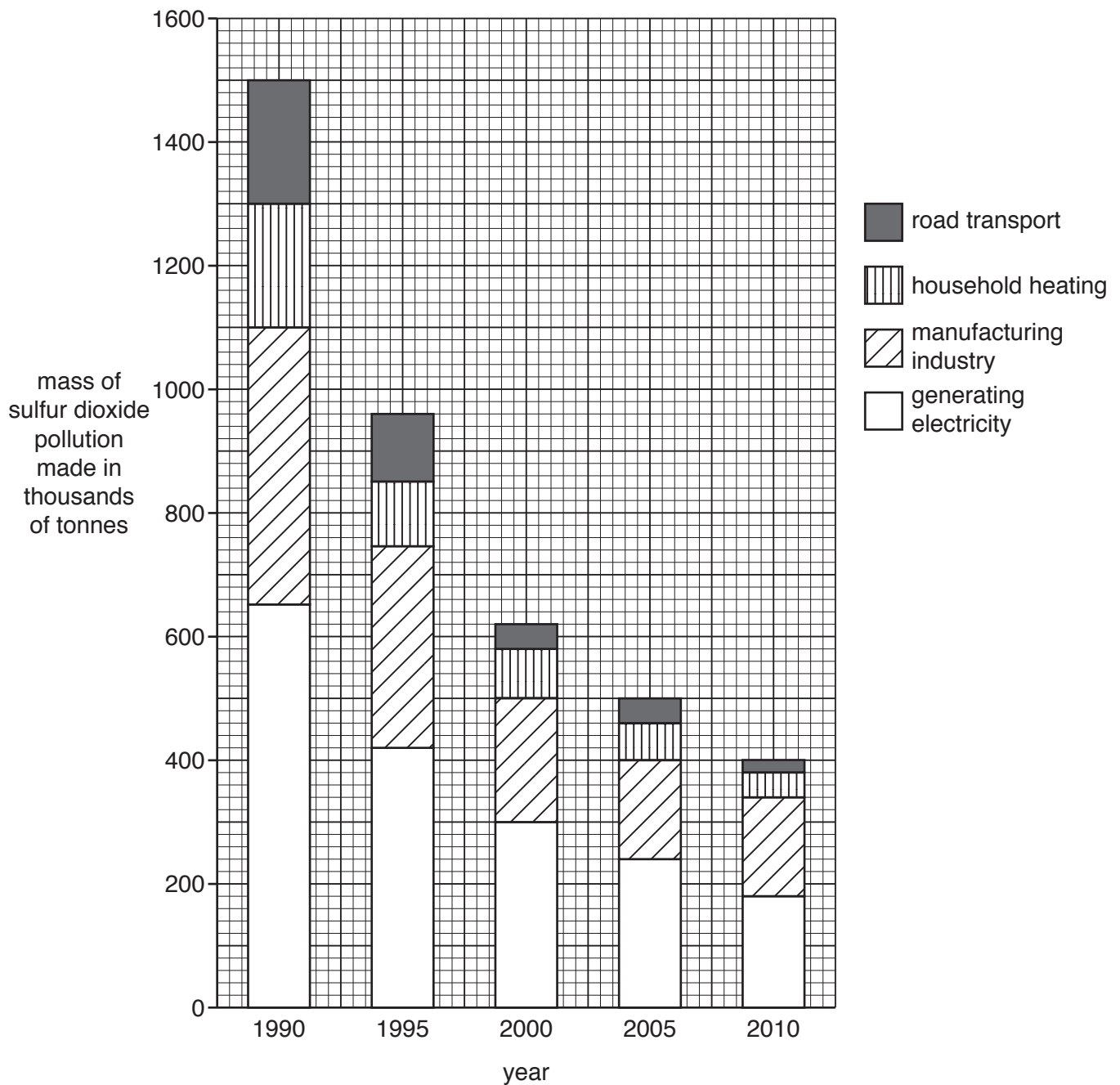

(i) What is the total mass of sulfur dioxide pollution made in 1990?

answer thousand tonnes [1]

(ii) Which way made the **most** sulfur dioxide pollution in 2000?

..... [1]

(iii) The total mass of sulfur dioxide pollution made between 1990 and 2010 has fallen.

Suggest possible reasons why.

.....
.....
.....
..... [2]

(b) Look at bar chart 2.

It shows the mass of **oxides of nitrogen** pollution made in France in different ways between 1990 and 2010.

bar chart 2

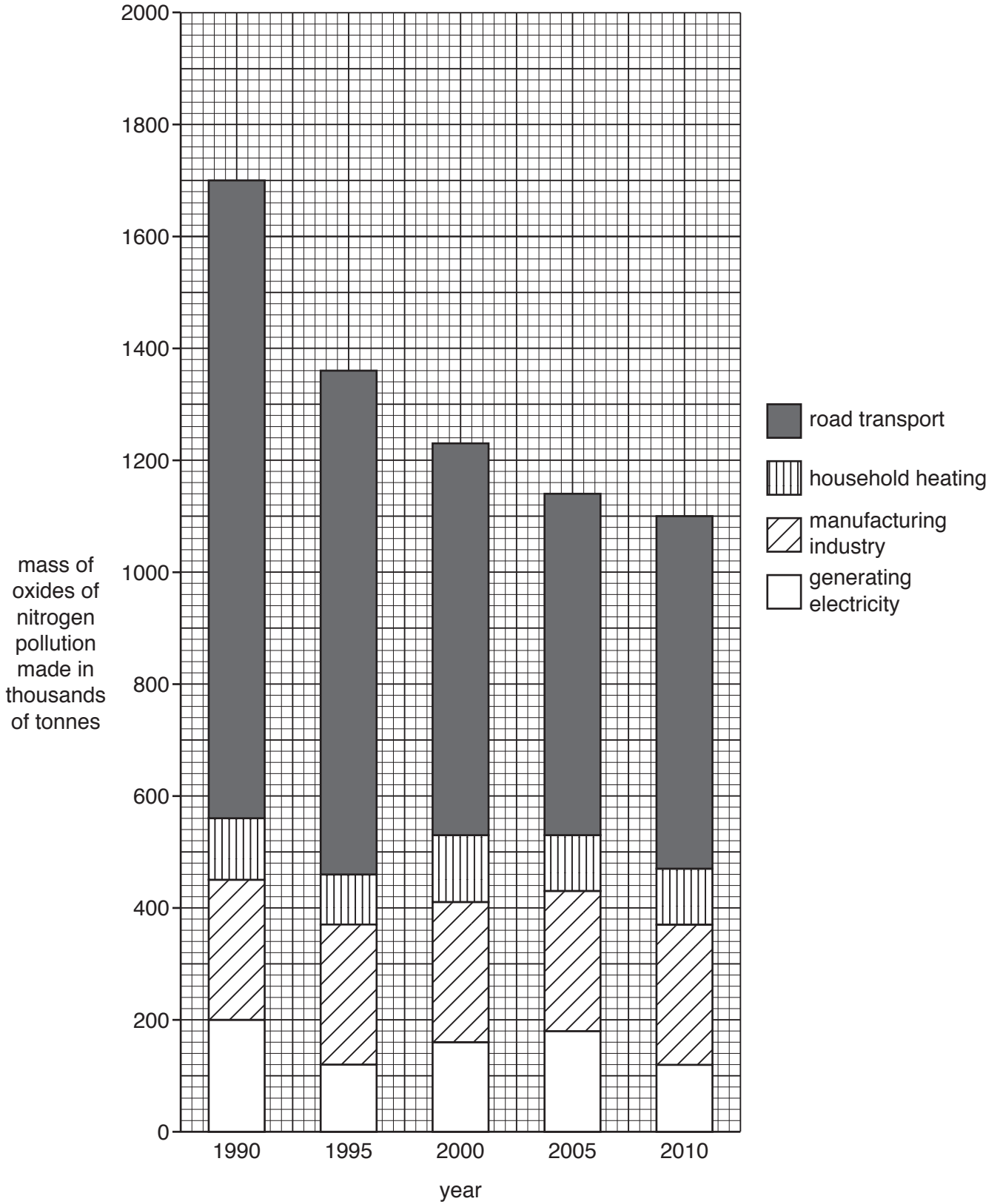

(i) What mass of oxides of nitrogen pollution was made by **road transport** in **2000**?

answer thousand tonnes [1]

(ii) What can you say about the mass of oxides of nitrogen pollution made by **manufacturing industry** between 1990 and 2010?

..... [1]

(iii) What **other** trends in the production of oxides of nitrogen pollution are shown on the bar chart?

.....
.....
.....
..... [2]

(c) Look at **both** bar chart 1 and bar chart 2.

Write about **two** differences in the ways that sulfur dioxide pollution and oxides of nitrogen pollution are made.

.....
.....
.....
..... [2]

END OF QUESTION PAPER



Copyright Information

OCR is committed to seeking permission to reproduce all third-party content that it uses in its assessment materials. OCR has attempted to identify and contact all copyright holders whose work is used in this paper. To avoid the issue of disclosure of answer-related information to candidates, all copyright acknowledgements are reproduced in the OCR Copyright Acknowledgements Booklet. This is produced for each series of examinations and is freely available to download from our public website (www.ocr.org.uk) after the live examination series.

If OCR has unwittingly failed to correctly acknowledge or clear any third-party content in this assessment material, OCR will be happy to correct its mistake at the earliest possible opportunity.

For queries or further information please contact the Copyright Team, First Floor, 9 Hills Road, Cambridge CB2 1GE.

OCR is part of the Cambridge Assessment Group; Cambridge Assessment is the brand name of University of Cambridge Local Examinations Syndicate (UCLES), which is itself a department of the University of Cambridge.

