

**OXFORD CAMBRIDGE AND RSA EXAMINATIONS
GCSE**

A503/01

MATHEMATICS A

Unit C (Foundation Tier)

FRIDAY 13 JUNE 2014: Morning

**DURATION: 1 hour 30 minutes
plus your additional time allowance**

MODIFIED ENLARGED

Candidate forename		Candidate surname	
-------------------------------	--	------------------------------	--

Centre number						Candidate number				
--------------------------	--	--	--	--	--	-----------------------------	--	--	--	--

Candidates answer on the Question Paper.

OCR SUPPLIED MATERIALS:

None

OTHER MATERIALS REQUIRED:

Scientific or graphical calculator

Geometrical instruments

Tracing paper (optional)

<p>You are permitted to use a calculator for this paper</p>
--

READ INSTRUCTIONS OVERLEAF

INSTRUCTIONS TO CANDIDATES

Write your name, centre number and candidate number in the boxes on the first page. Please write clearly and in capital letters.

Use black ink. HB pencil may be used for graphs and diagrams only.

Answer ALL the questions.

Read each question carefully. Make sure you know what you have to do before starting your answer.

Your answers should be supported with appropriate working. Marks may be given for a correct method even if the answer is incorrect.

Write your answer to each question in the space provided. Additional paper may be used if necessary but you must clearly show your candidate number, centre number and question number(s).

INFORMATION FOR CANDIDATES

The number of marks is given in brackets [] at the end of each question or part question.

Your quality of written communication is assessed in questions marked with an asterisk (*).

Use the π button on your calculator or take π to be 3.142 unless the question says otherwise.

The total number of marks for this paper is 100.

Any blank pages are indicated.

FORMULAE SHEET: FOUNDATION TIER

Area of trapezium = $\frac{1}{2} (a + b)h$

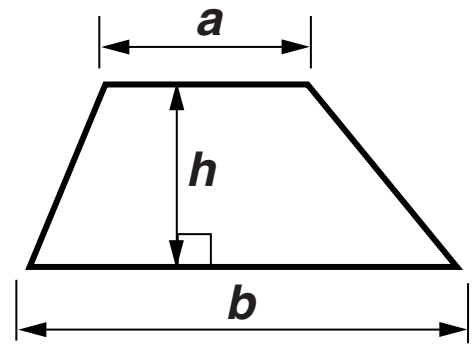

Volume of prism = (area of cross-section) \times length

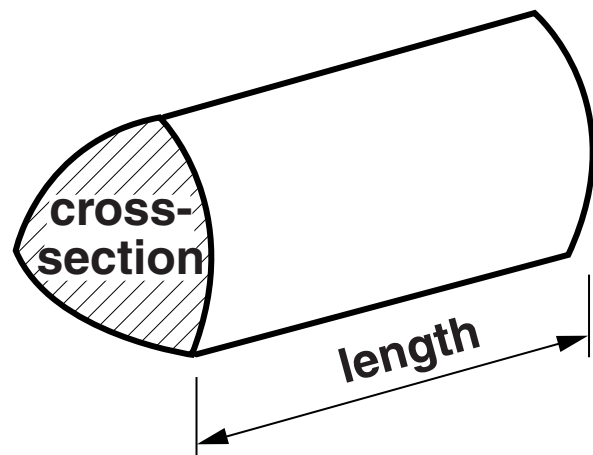

Answer ALL the questions.

1 Sam has these number cards.

5

3

2

0

6

1

Complete the following problems using Sam's number cards.

(a) $54 + \square\square = 80$ [1]

(b) $7 \times \square = 42$ [1]

(c) $\frac{16}{40} = \frac{2}{\square}$ [1]

(d) $3 - \square = -2$ [1]

(e) $\square 0 \div \square = \square$ [2]

2 Mr and Mrs Parsons and their three children go to the cinema.

(a) The show starts at 18:20 with 20 minutes of adverts and then 5 minutes of film previews before the movie begins.

(i) At what time does the movie begin?

(a)(i) _____ [1]

(ii) The movie lasts for 1 hour and 50 minutes.

At what time does the movie finish?

(ii) _____ [1]

(b) The prices for the tickets at the cinema are shown below.

Adult ticket	£8.20 each
Child ticket	£4.90 each
Family ticket (for 2 adults and 3 children)	£26.00

How much does the Parsons family save by buying a family ticket rather than buying separate adult and child tickets?

(b) £ _____ [3]

3 A sandwich shop has these 40 sandwiches for sale one morning.

- 10 tuna**
- 20 ham**
- 7 chicken**
- 3 cheese**

(a) A sandwich is chosen at random from these sandwiches.

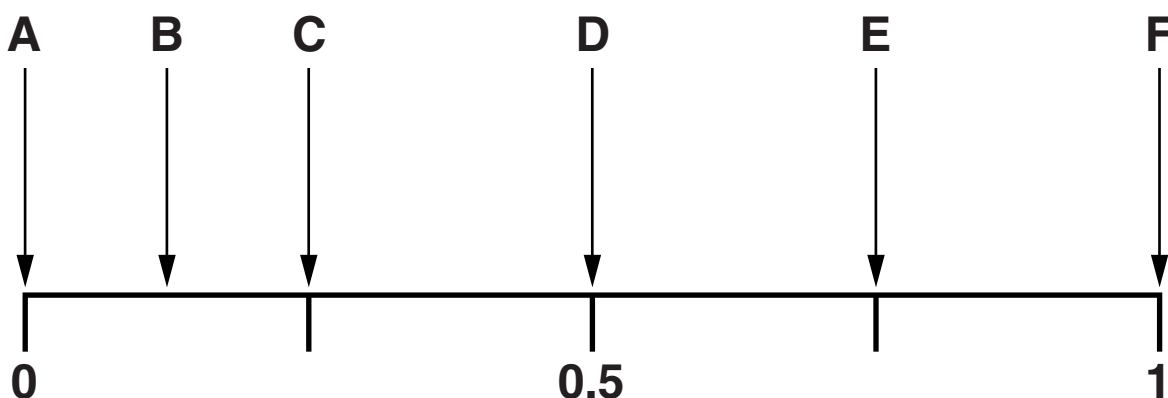

Which arrow shows the probability that the sandwich is

(i) tuna,

(a)(i) Arrow _____ [1]

(ii) beef,

(ii) Arrow _____ [1]

(iii) ham?

(iii) Arrow _____ [1]

(b) By the afternoon, 30 of the sandwiches have been sold.

Here are some facts about the 10 sandwiches left.

There are three types of sandwich left.

If one sandwich is chosen at random, it is even that it will be tuna.

If one sandwich is chosen at random, it is less likely to be chicken than cheese.

Work out one possible combination of the types and numbers of the 10 sandwiches left. [3]

4 (a) Calculate.

(i) $5.6^2 + 6.9 - 8.2$

(a)(i) _____ [1]

(ii) $\sqrt{65.61}$

(ii) _____ [1]

**(b) Juliet buys 5 identical jars of coffee.
She pays £22 altogether.**

How much does each jar cost?

(b) £ _____ [1]

5 (a) A car is 15 feet long.

In the list below, ring the number of metres that is about 15 feet.

1.5 m

3 m

15 m

5 m

7.5 m

[1]

(b) Here is a rule for converting miles to kilometres.

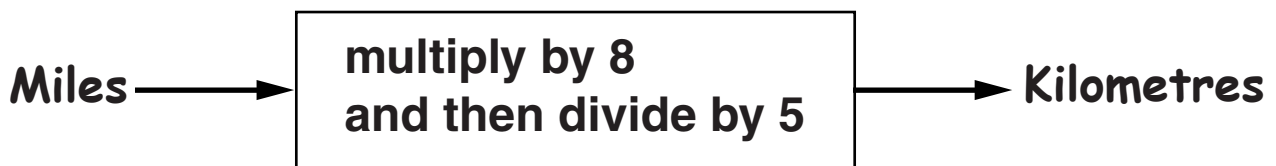

(i) Convert 60 miles to kilometres.

(b)(i) _____ km [1]

(ii) Convert 400 kilometres to miles.

(ii) _____ miles [2]

- 6 Here are some places in a village drawn on a coordinate grid.

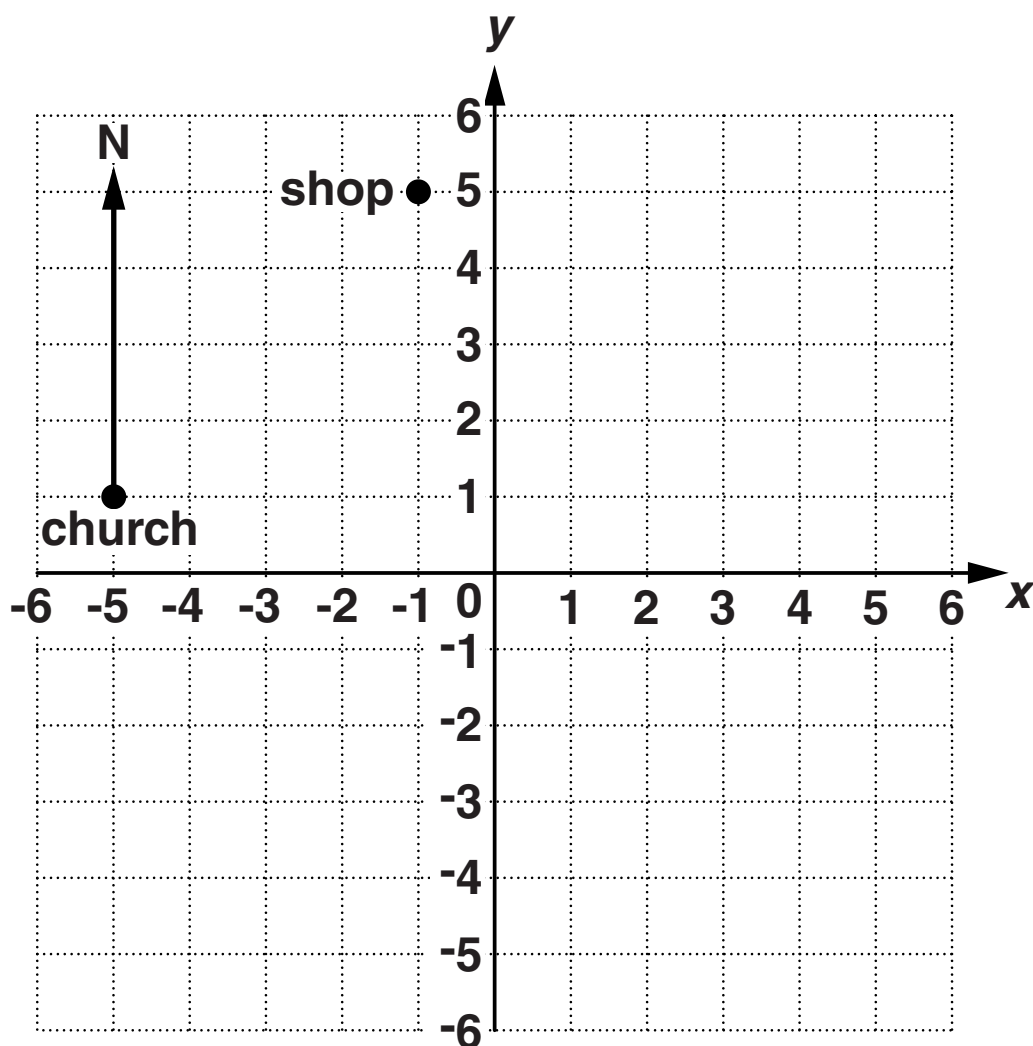

(a) Write down the coordinates of the church.

(a) (_____ , _____) [1]

(b) The post office is at (3, -4).

Plot this point and label it P.

[1]

(c) Write down the bearing of the shop from the church.

(c) _____ ° [1]

(d) The school lies directly south of the shop and is closer to the church than the post office.

Plot a possible position for the school and label it S.

Write down the coordinates of your point S.

(d) (_____ , _____) [2]

7 Amir and Jasmine are making shapes using cubes.

(a) Amir arranges some of the cubes into the shape shown below.

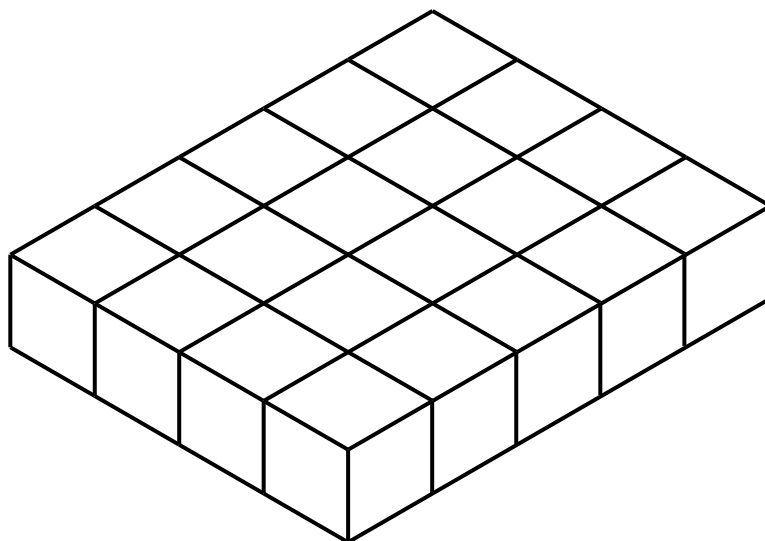

How many cubes has he used for this shape?

(a) _____ [1]

(b) Amir places 5 MORE identical layers of cubes on top of the shape shown above.

Write down the number of cubes in his completed shape.

(b) _____ [1]

- (c) Jasmine arranges some of the cubes into the shape shown below.
There is one more cube on the bottom layer than on the top layer.

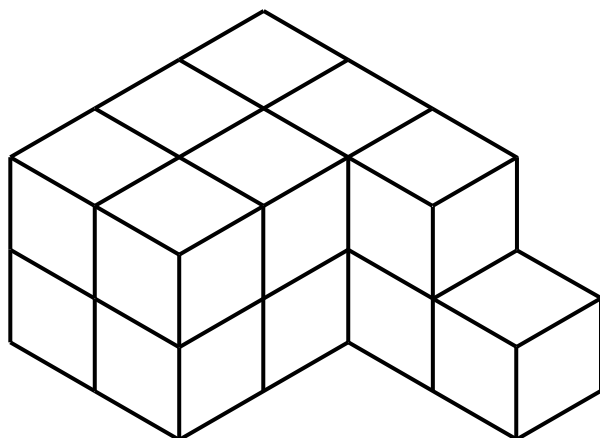

How many cubes are in her arrangement?

(c) _____ [1]

(d) Work out the SMALLEST number of cubes that Jasmine needs to add to her shape in part (c) so that she has

(i) a cuboid,

(d)(i) _____ [2]

(ii) a cube.

(ii) _____ [2]

8 (a) Write 34.7 correct to the nearest whole number.

(a) _____ [1]

(b) Write 3.96 correct to 1 decimal place.

(b) _____ [1]

(c) Write 124.923 correct to 2 significant figures.

(c) _____ [1]

9 (a) Simplify fully.

(i) $7 \times y \times 9$

(a)(i) _____ [1]

(ii) $\frac{10t}{2t}$

(ii) _____ [1]

(iii) $a + 6b - 4a + 2b$

(iii) _____ [2]

(b) Solve these equations.

(i) $\frac{x}{6} = 30$

(b)(i) _____ [1]

(ii) $6x + 1 = 16$

(ii) _____ [2]

(c) Multiply out.

$4(3x + 5)$

(c) _____ [1]

10 (a) (i) Change 5.6 kilograms into grams.

(a)(i) _____ g [1]

(ii) Change 32 millimetres into centimetres.

(ii) _____ cm [1]

**(b) Alex has a 1.5 litre bottle of squash.
He makes 4 drinks each day using 30 ml of the
squash for each drink.**

**How much squash is left in the bottle at the end
of 5 days?**

(b) _____ ml [3]

11 (a) Peter, a window cleaner, earns 60p for each window he cleans and £2.20 for each conservatory he cleans.

(i) One morning, he cleaned 90 windows and 5 conservatories.

Work out how much Peter earned.

(a)(i) £ _____ [2]

**(ii) The following day Peter earned £133.60 in total.
He cleaned 16 conservatories altogether that day.**

Work out the number of windows Peter cleaned that day.

(ii) _____ [3]

(b) (i) In 2012 Peter's total earnings were £22 500.

**Work out how much Peter earned, on average,
for each month in 2012.**

(b)(i) £ _____ [2]

(ii) In 2013 his earnings increased by 4%.

Calculate 4% of £22 500.

(ii) £ _____ [2]

12 (a) At Willingboro Academy, pupils are either right-handed or left-handed, but not both. The probability that a pupil chosen at random from Willingboro Academy is left-handed is 0.1.

(i) Write down the probability that a pupil chosen at random from the Academy is right-handed.

(a)(i) _____ [1]

(ii) The Academy has 780 pupils altogether.

How many of these pupils are LEFT-HANDED?

(ii) _____ [2]

(b) At St Michael's School, the probability that a pupil chosen at random is left-handed is $\frac{1}{12}$.

There are 912 pupils at St Michael's School.

Which of St Michael's School and Willingboro Academy has the greater number of left-handed pupils, and by how many?

**(b) _____ has
_____ more left-handed pupils.
[3]**

13 (a) Work these out, giving your answers as fractions.

(i) $\frac{3}{5} \times \frac{1}{4}$

(a)(i) _____ [1]

(ii) $\frac{2}{7} \div 3$

(ii) _____ [1]

(b) Complete this calculation.

$$\frac{1}{3} - \frac{1}{5}$$

$$= \frac{\square}{15} - \frac{\square}{\square}$$

$$= \frac{\square}{\square}$$

[2]

14 Here is a plan of Bill's living room.

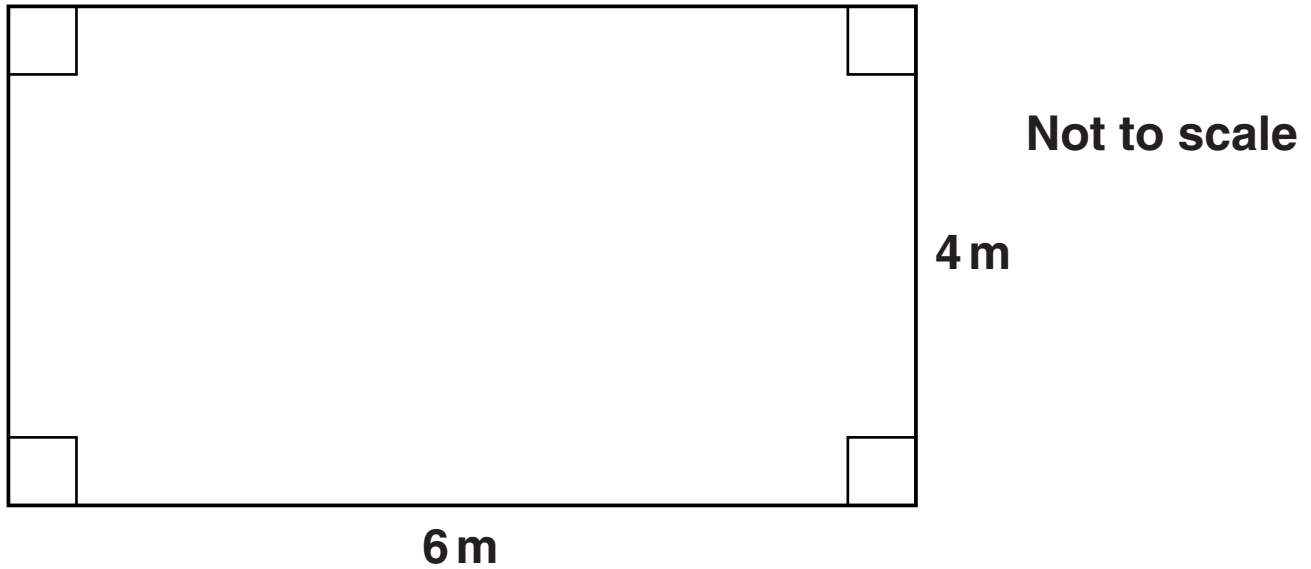

Bill is fitting wooden flooring and edging strip in his living room.

The prices are shown in the table.

Item	Cost
Wooden flooring	£21.75 for each square metre
Edging strip	£4.50 for each metre length

Bill buys wooden flooring to cover the total FLOOR AREA of his room and edging strip to fit around the PERIMETER of the room.

Calculate the total cost of the flooring and edging strip for Bill's living room.

£ _____ [5]

**15 An empty water tank is to be filled with water and then emptied.
For the first 4 minutes it is filled at a constant rate of 20 litres per minute.
For the next 3 minutes it is filled at a constant rate of 15 litres per minute.
It is then left for 2 minutes.
It is then emptied at a constant rate of 25 litres per minute.**

Show this information on the grid opposite.

[4]

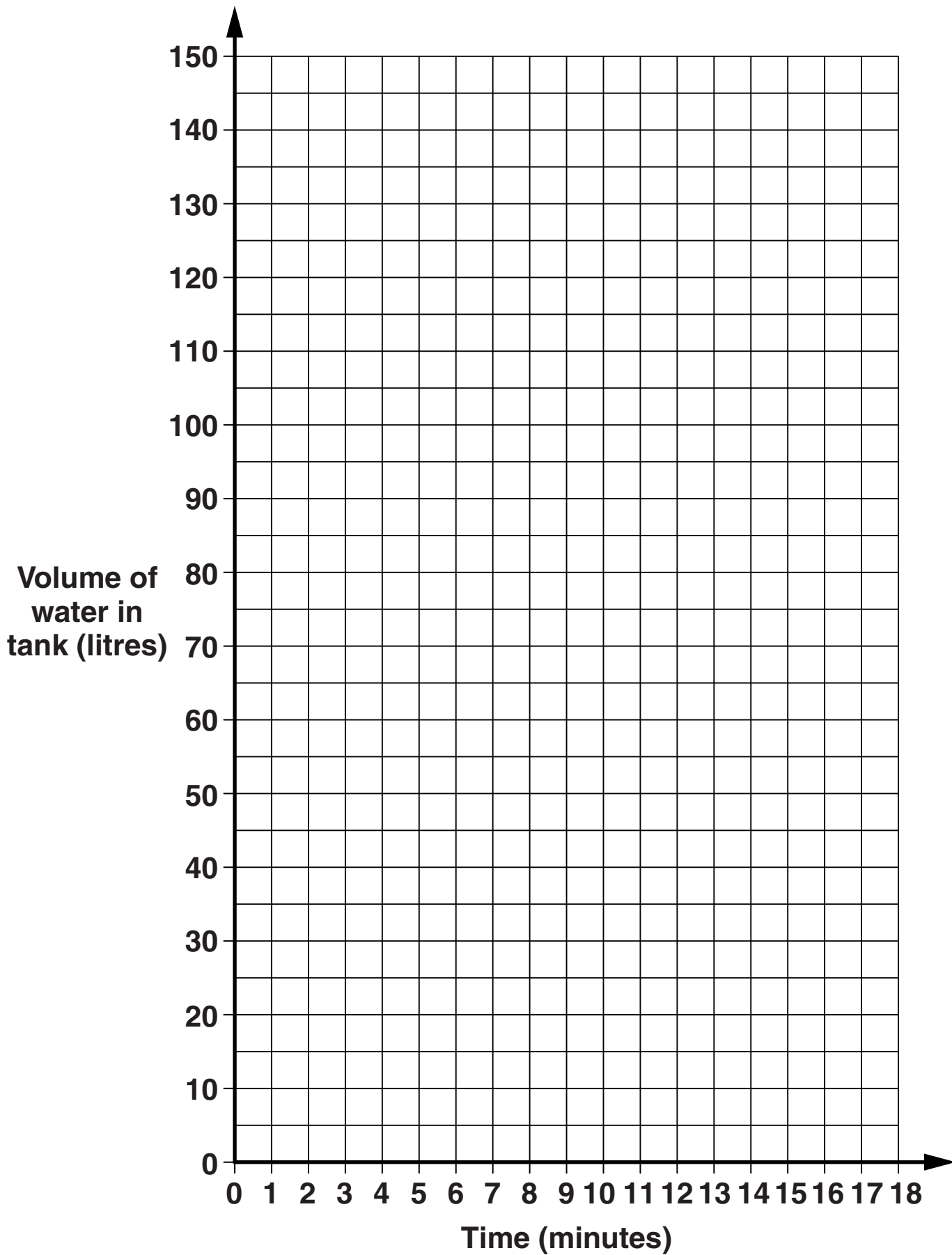

16 Simon is asked to solve an equation.

Here is his solution.

$$2(3x - 1) = 7$$

$$6x - 2 = 14$$

$$6x = 14 - 2$$

$$6x = 12$$

$$x = \frac{1}{2}$$

Simon has made THREE errors.

(a) Explain the errors that he has made.

1 _____

2 _____

3 _____

_____ **[3]**

(b) Show by substitution that $x = \frac{1}{2}$ is NOT the solution to the equation $2(3x - 1) = 7$.

[1]

- 17** A random sample of students in a school is asked about their lunch arrangements. The table shows their responses.

	School dinner	Sandwiches	Home	Local shop
Frequency	82	58	36	24

- (a) (i) Complete the table of relative frequencies for these data. Give each answer as a decimal.

	School dinner	Sandwiches	Home	Local shop
Relative frequency				

[3]

- (ii) Explain why it is reasonable to use the relative frequencies as estimates of probability.

[1]

(b) Use the data to work out an estimate of the probability that a student, chosen at random, either goes home or goes to the local shop for lunch.

(b) _____ [2]

(c) There are 3200 students in the school altogether.

How many of these would you expect to have a school dinner?

(c) _____ [2]

- 18 A gate is made from strips of metal.
The outline of the gate is a rectangle topped by a semicircle.

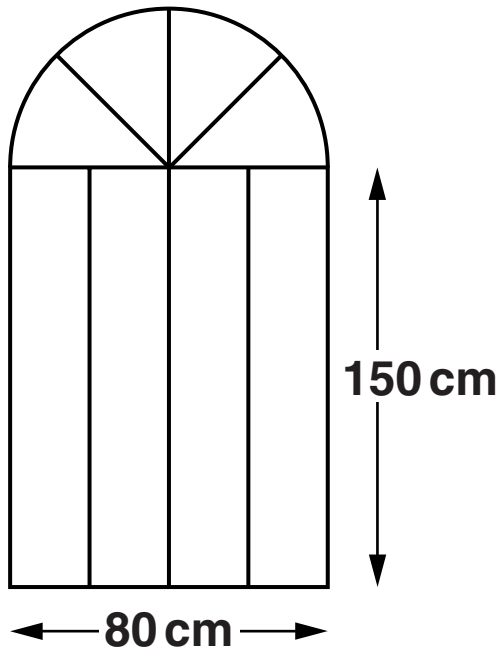

Not to
scale

- (a) Explain why the maximum height of the gate is 190 cm.

[1]

**(b)* Work out the total length of metal strip needed to make the gate.
Give your answer correct to 3 significant figures.**

(b) _____ cm [7]

END OF QUESTION PAPER



Copyright Information

OCR is committed to seeking permission to reproduce all third-party content that it uses in its assessment materials. OCR has attempted to identify and contact all copyright holders whose work is used in this paper. To avoid the issue of disclosure of answer-related information to candidates, all copyright acknowledgements are reproduced in the OCR Copyright Acknowledgements Booklet. This is produced for each series of examinations and is freely available to download from our public website (www.ocr.org.uk) after the live examination series.

If OCR has unwittingly failed to correctly acknowledge or clear any third-party content in this assessment material, OCR will be happy to correct its mistake at the earliest possible opportunity.

For queries or further information please contact the Copyright Team, First Floor, 9 Hills Road, Cambridge CB2 1GE.

OCR is part of the Cambridge Assessment Group; Cambridge Assessment is the brand name of University of Cambridge Local Examinations Syndicate (UCLES), which is itself a department of the University of Cambridge.

